

STANDARD CONCRETE ELEPHANT DOOR DRAWINGS

BOTTOM ROLLING ACOUSTIC ELEPHANT DOOR

PREPARED FOR:
N/A

SUB CONTRACTOR:
GPS SPECIALTY DOORS
5 JUST RD
FAIRFIELD, NJ 07004

THIS DRAWING IS THE PROPERTY OF
GPS
SPECIALTY DOORS
5 JUST ROAD, FAIRFIELD, NJ 07004
(973) 775-6200 FAX: (973) 775-2177

CONCRETE ACOUSTIC STUDIO DOOR

COVER SHEET

Sheet #	Description	Drawing Created Date	Drawing created by	Revision Number	Revision date
SD0	COVER PAGE	7/5/2017	DKH		
SD1	PLAN, ELEVATION AND SECTION	7/5/2017	DKH		
SD2	SECTION DETAILS	7/5/2017	DKH		
SD3	FRAMING LAYOUT, GENERAL	7/5/2017	DKH		
SD4	MOTOR MOUNTING DETAILS	7/5/2017	DKH		
SD5	LIMIT SWITCH AND SAFETY EDGE DETAILS	7/5/2017	DKH		

PROPRIETARY NOTICE
THIS DRAWING CONTAINS PROPRIETARY INFORMATION OF GPS SPECIALTY DOORS AND IS THE PROPERTY OF GPS SPECIALTY DOORS. IT IS TO BE USED ONLY FOR THE PROJECT AND LOCATION SPECIFICALLY IDENTIFIED HEREIN. ANY REPRODUCTION, DISSEMINATION OR USE WITHOUT THE WRITTEN AUTHORIZATION OF GPS SPECIALTY DOORS IS STRICTLY PROHIBITED.

PROJECT: STANDARD ELEPHANT DOOR DRAWINGS
 LOCATION: N/A
 CUSTOMER: N/A
 ARCHITECT: N/A
 ENGINEER: N/A
 SCALE: N/A
 DRAWN BY: DKH
 CHECKED BY: N/A
 APPROVED: N/A
 DATE: 7/5/2017
 PROJECT NO: STD
 SHEET NO: SD0

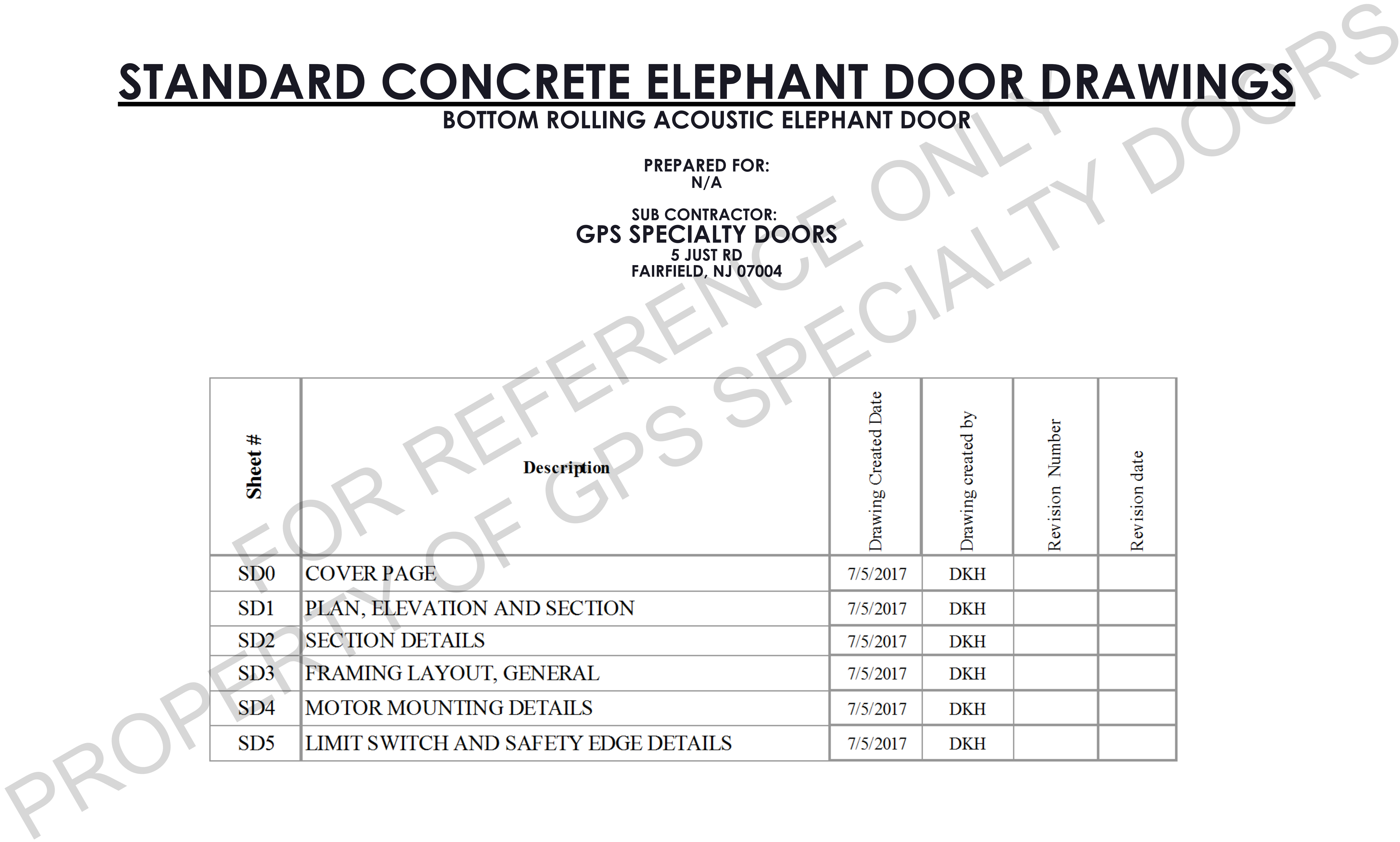

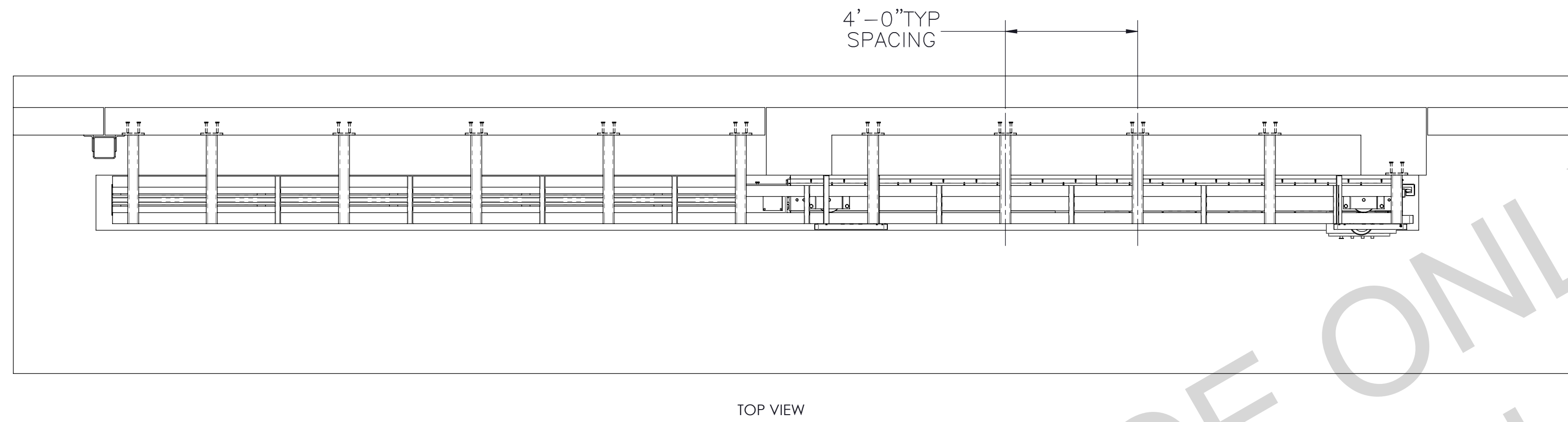

- NOTE:**
1. ALL DOOR PANELS TO BE CAST IN THE FIELD (BY OTHERS)
 2. GENERAL CONTRACTOR TO SUPPLY AND DEMOLISH CASTING SLAB
 3. ALL EXPOSED METAL SURFACES SHALL RECEIVE (1) COAT SHOP PRIMER. ALL METAL SURFACES THAT WILL COME IN CONTACT WITH CONCRETE SHALL NOT BE PAINTED. ALL FINISH PAINT IS BY OTHERS IN THE FIELD.
 4. CONCRETE SHALL HAVE A MINIMUM OF 3,000 PSI WITH A 3/4" AGGREGATE PUMP MIX (BY OTHERS)
 5. REBAR SHALL BE GRADE 60 MINIMUM (BY OTHERS)
 6. ALL STEEL SHALL BE GRADE A - 36 (DUAL SPECIFICATIONS OK)
 7. ALL STRUCTURAL STEEL DIMENSIONS TAKEN FROM "PART 1: STRUCTURAL SHAPES." MANUAL OF STEEL CONSTRUCTION: ALLOWABLE STRESS DESIGN. CHICAGO, IL: AISC, 1995. NINTH ED.
 8. SOME DETAILS INTENTIONALLY LEFT OUT FOR CLAIRTY AND ARE INDICATED ON SPECIFIC DRAWING VIEW

THE DOOR ASSEMBLY SHALL PROVIDE EXTERIOR TO INTERIOR NOISE REDUCTION SUFFICIENT TO MEET NC 20. IT IS ESTIMATED THAT THIS REQUIREMENT CAN BE MET WITH AN ASSEMBLY WITH AN STC RATING OF 56.

BUILDING DIMENSIONS OBTAINED FROM CUSTOMER SUPPLIED ARCHITECTURAL AND STRUCTURAL DRAWINGS. DETAILS PROVIDED HERE ARE FOR GENERAL REFERENCE ONLY.

OUTRIGGER EMBED, CONCRETE, TYP
DETAIL SHOWS TYPICAL CONSTRUCTION
EMBEDS, OUTRIGGER TYPE, PLACEMENT AND DETAILS
TO BE DETERMINED BASED OFF OF ANALYSIS, CUSTOMER
PROVIDED ARCHITECTURAL AND STRUCTURAL DRAWINGS

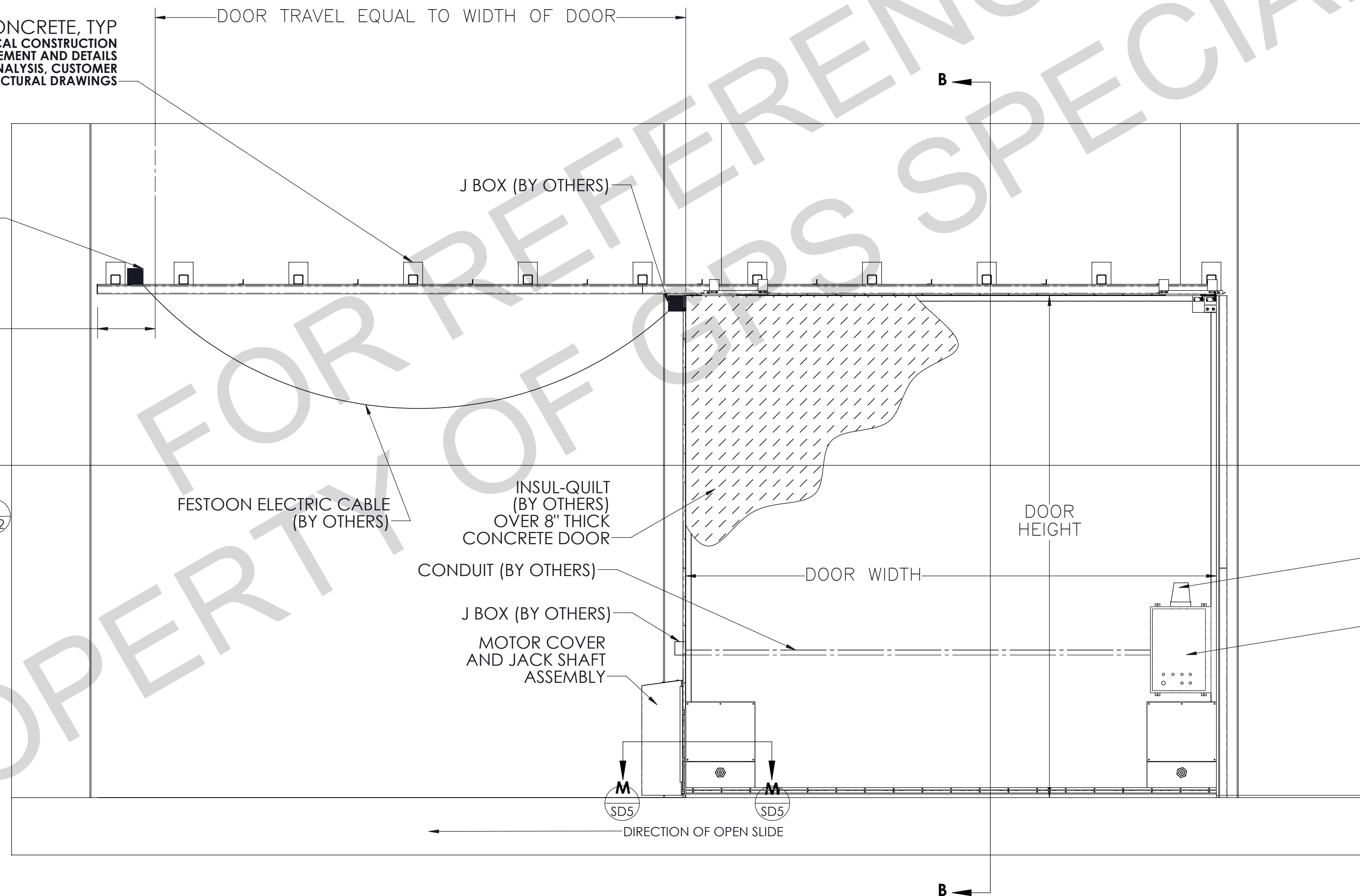

INTERIOR ELEVATION
(DOOR SHOWN IN CLOSED POSITION)

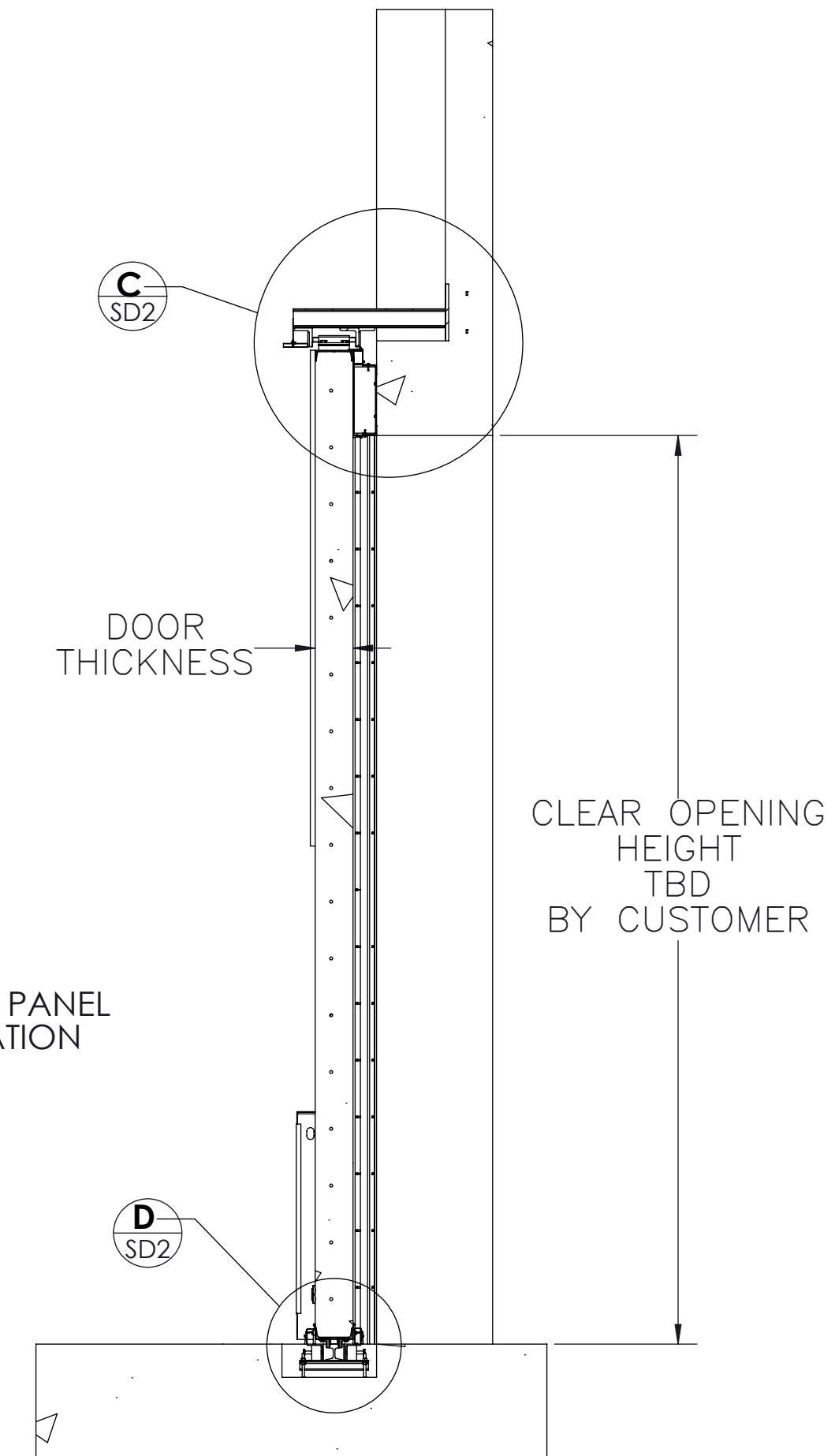

SECTION B-B
SCALE 1 : 32

PROJECT: STANDARD ELEPHANT DOOR DRAWINGS		PROJECT NO: STD	
LOCATION: N/A	DATE: N/A	DATE: N/A	DATE: N/A
CUSTOMER: N/A	SCALE: N/A	CHECKED BY: DKH	DATE: 7/5/2017
ARCHITECT: E - STS	DRAWN BY: N/A	APPROVED: SDI	DATE: N/A
COLOR CODE: N/A	PROJECT NO: STD	DATE: N/A	DATE: N/A
PROPRIETARY NOTICE: THIS DRAWING CONTAINS PROPRIETARY INFORMATION OF GPS SPECIALTY DOORS AND ITS RECEIPT OR REPRODUCTION OF ANY PART OF THIS DRAWING IS STRICTLY PROHIBITED. ALL RIGHTS OF DESIGN AND INVENTION AND ANY REPRODUCTION, REPLICATION OR USE WITHOUT SPECIFIC WRITTEN AUTHORIZATION FROM GPS SPECIALTY DOORS IS STRICTLY PROHIBITED.		NO.	DATE
		NAME	REGION

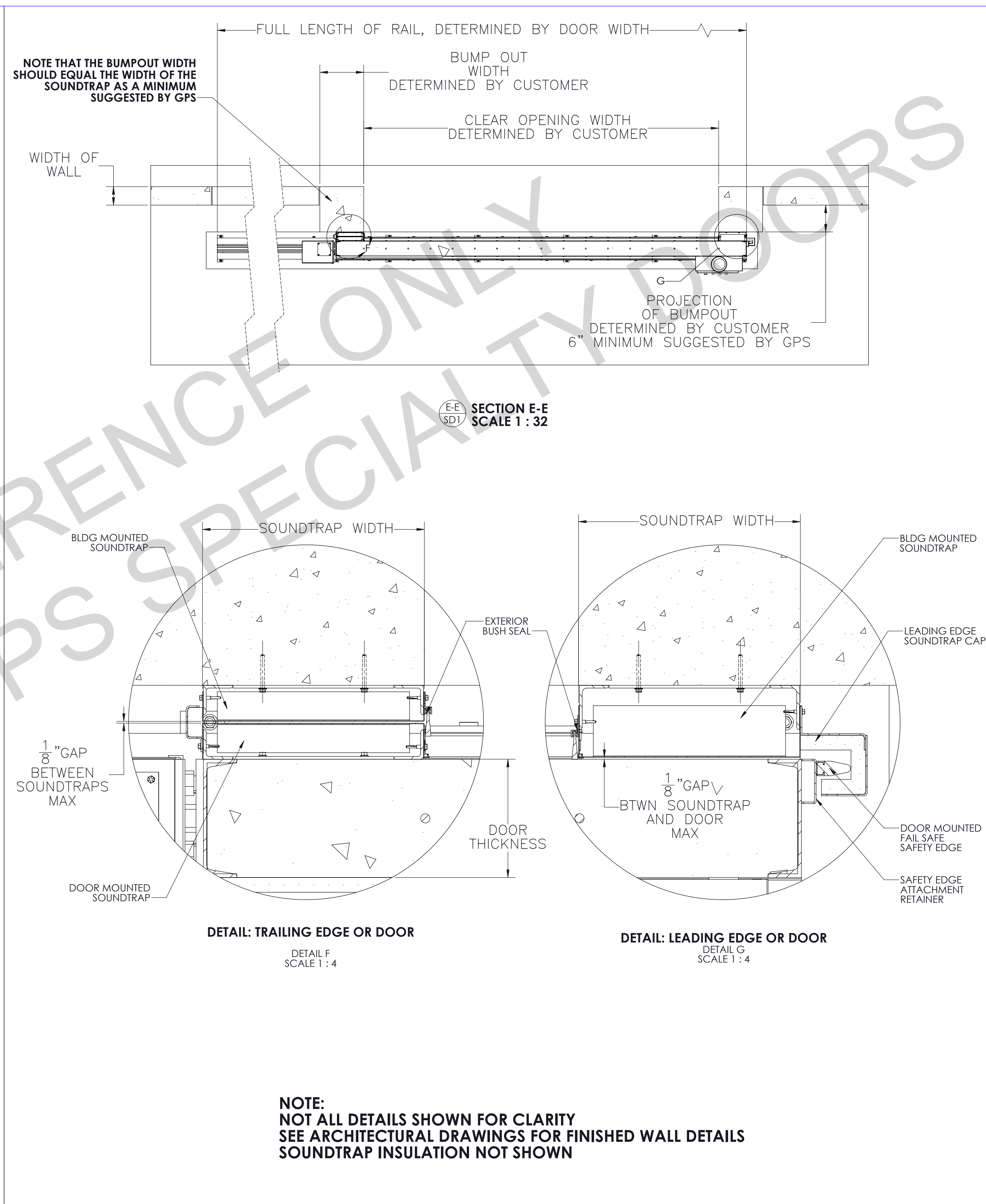
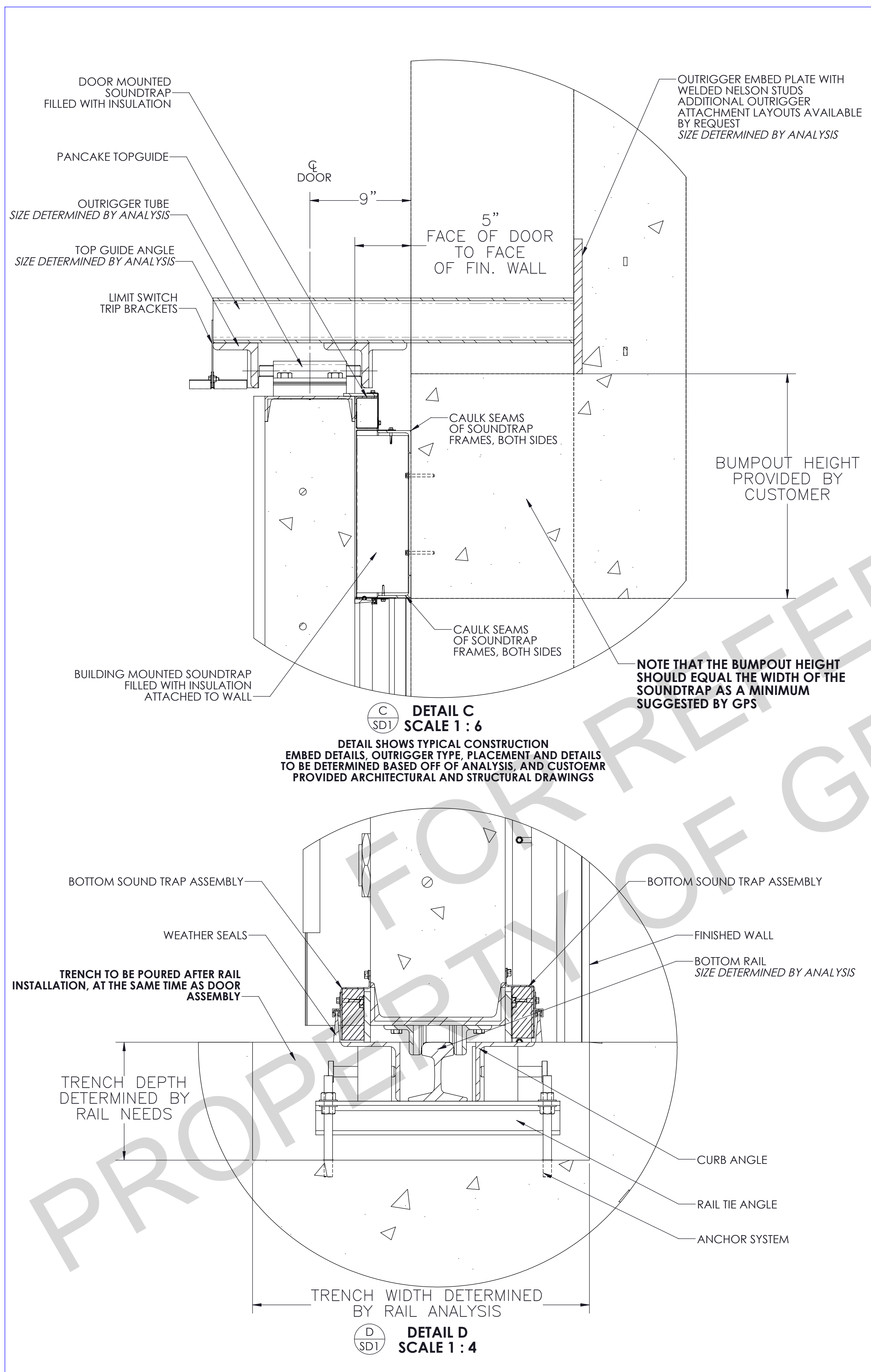

THIS DRAWING IS THE PROPERTY OF
GPS
 SPECIALTY DOORS
 5 JUST ROAD, FAIRFIELD, NJ 07004
 (973) 776-6200 FAX: (973) 776-2177

CONCRETE ACOUSTIC STUDIO DOOR

SECTION DETAILS

PROPRIETARY NOTICE
 THIS DRAWING CONTAINS PROPRIETARY INFORMATION OF GPS SPECIALTY DOORS AND ITS RECEIPT OR MANUFACTURE HEREOF SHALL CONSTITUTE AN INFRINGEMENT OF GPS SPECIALTY DOORS PATENTS. ALL RIGHTS OF DESIGN AND INVENTION AND ANY REPRODUCTION, DISCLOSURE OR USE WITHOUT SPECIFIC WRITTEN AUTHORIZATION FROM GPS SPECIALTY DOORS IS STRICTLY PROHIBITED.

NO.	DATE	REVISION	NAME

PROJECT: STANDARD ELEPHANT DOOR DRAWINGS	SCALE: N/A	N/A	N/A
LOCATION: N/A	DATE: 7/5/2017	DATE: N/A	DATE: N/A
CUSTOMER: N/A	DRAWN BY: DKH	CHECKED BY: N/A	APPROVED BY: N/A
ARCHITECT: N/A	PROJECT NO: SD2	DATE: N/A	DATE: N/A
ENGINEER: E - SDT	PROJECT CODE: STD	DATE: N/A	DATE: N/A

NOTE:
 NOT ALL DETAILS SHOWN FOR CLARITY
 SEE ARCHITECTURAL DRAWINGS FOR FINISHED WALL DETAILS
 SOUNDTRAP INSULATION NOT SHOWN

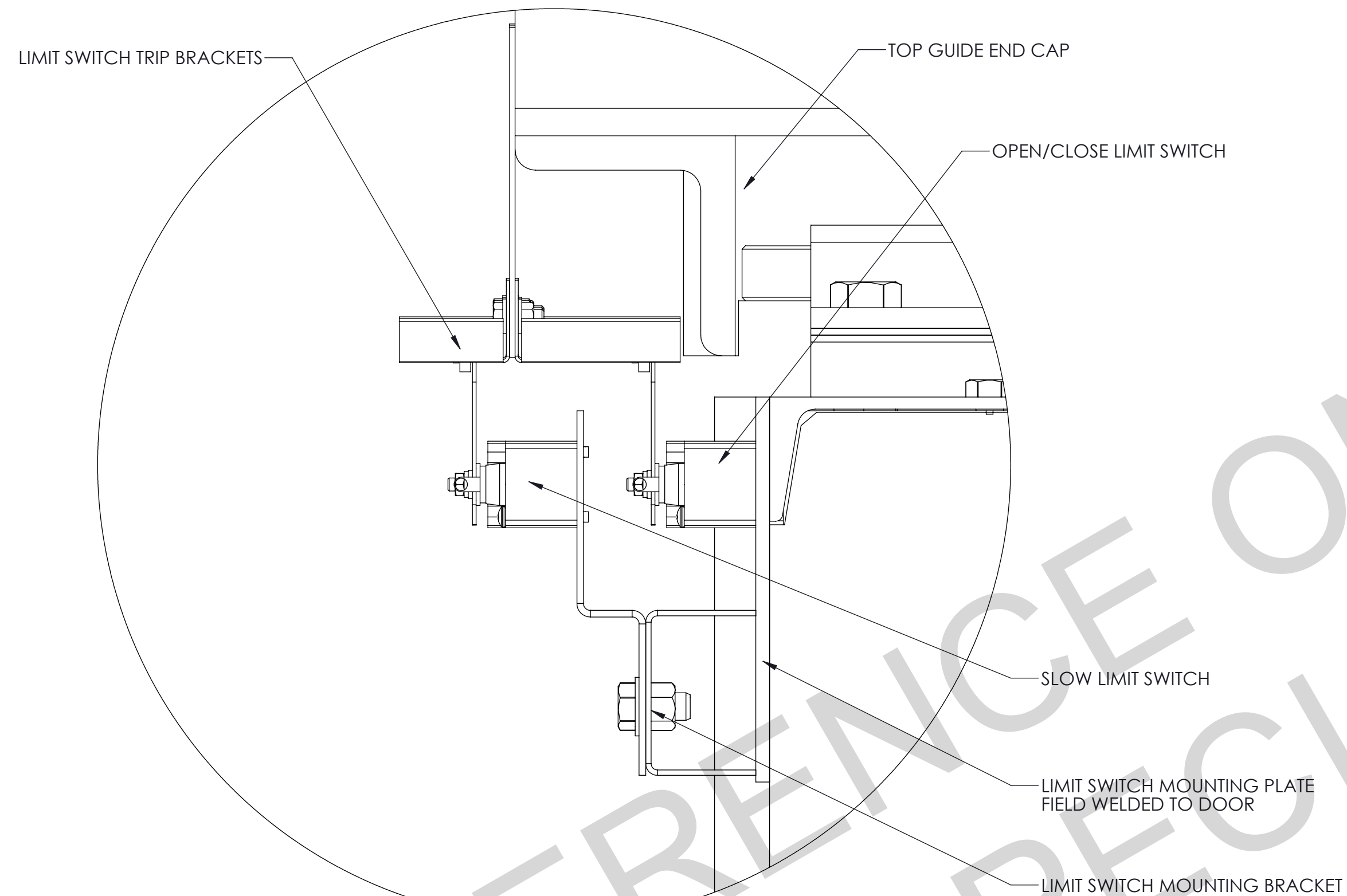
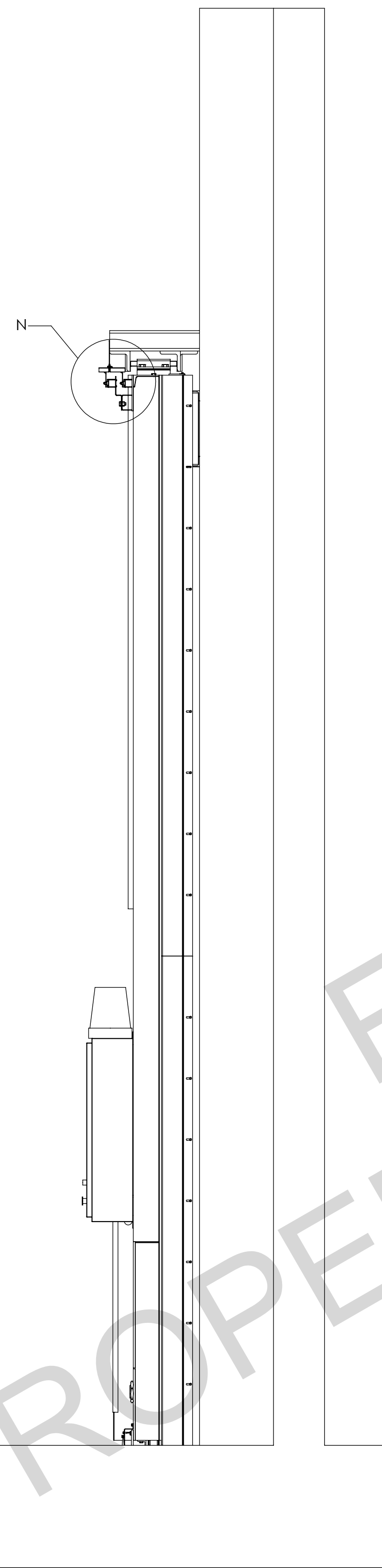

SIDE VIEW: LIMIT SWITCH LAYOUT
 DETAIL N
 SCALE 1 : 2

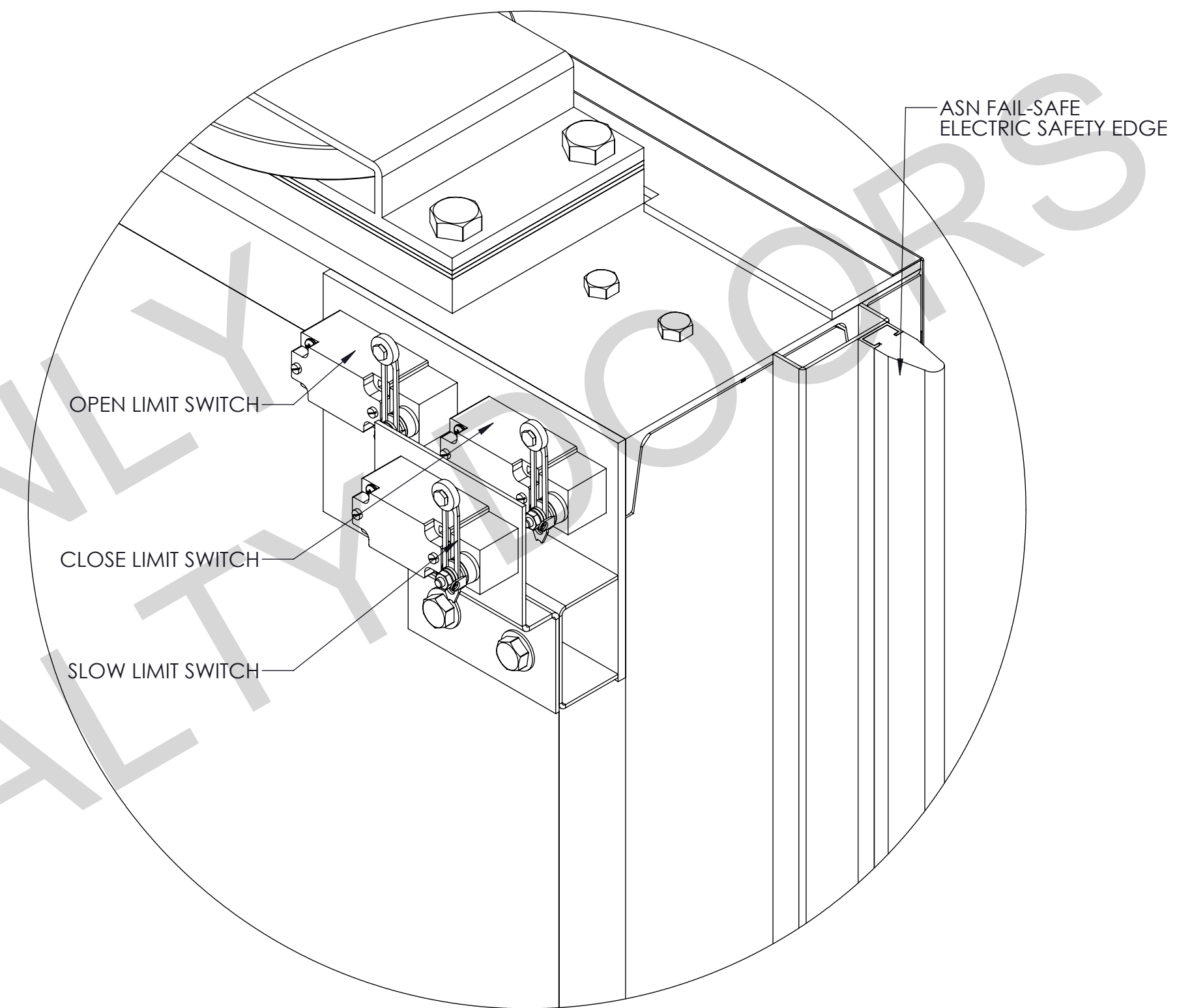

ISO VIEW: LIMIT SWITCH LAYOUT
 DETAIL R
 SCALE 1 : 3

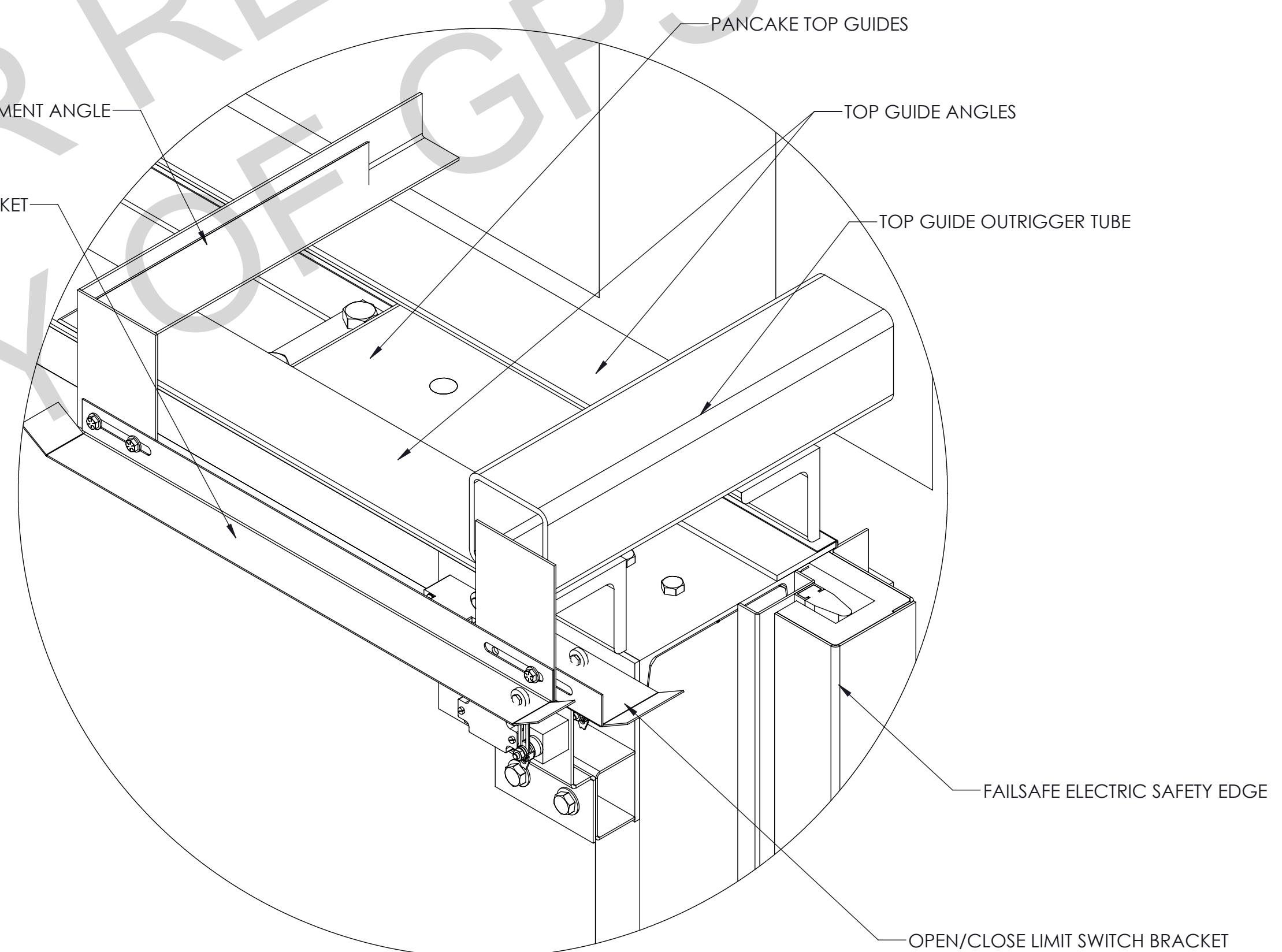

ISO VIEW: TRIP BRACKET LAYOUT
 DETAIL T
 SCALE 1 : 4

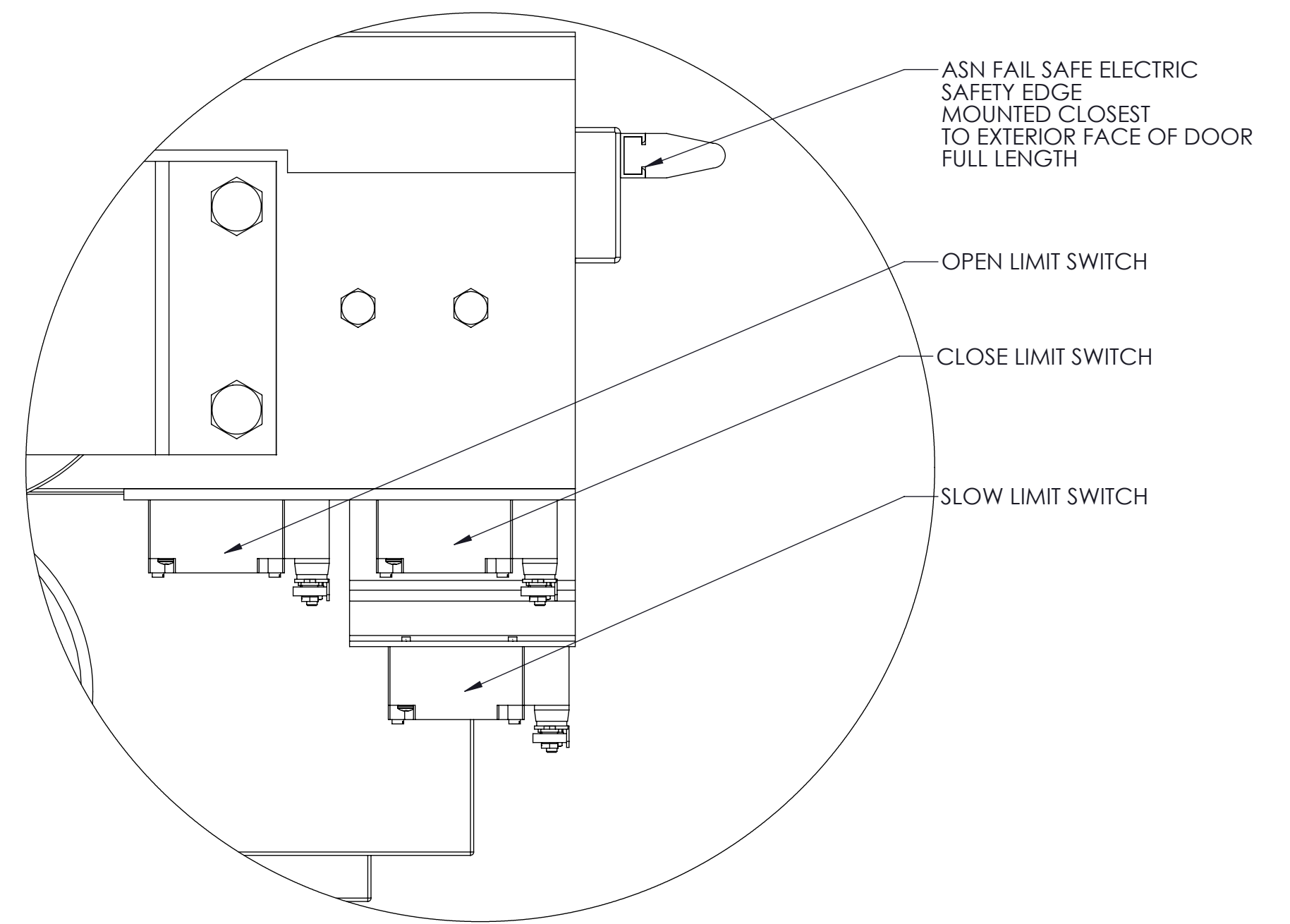

TOP VIEW: LIMIT SWITCH LAYOUT
 DETAIL T
 SCALE 1 : 3

THIS DRAWING IS THE PROPERTY OF
GPS
 SPECIALTY DOORS
 5 JUST ROAD, FAIRFIELD, N.J. 07004
 (973) 775-6200 FAX: (973) 775-2177

CONCRETE ACOUSTIC STUDIO DOOR
 SAFETY EDGE AND LIMIT SWITCH DETAILS

PROPRIETARY NOTICE
 THIS DRAWING CONTAINS PROPRIETARY INFORMATION OF GPS SPECIALTY DOORS AND ITS RECEIPT OR REPRODUCTION BY ANY PARTY WITHOUT THE WRITTEN AUTHORIZATION OF GPS SPECIALTY DOORS IS STRICTLY PROHIBITED.
 ALL RIGHTS OF DESIGN AND INVENTION AND ANY REPRODUCTION, DISCLOSURE OR USE WITHOUT SPECIFIC WRITTEN AUTHORIZATION FROM GPS SPECIALTY DOORS IS STRICTLY PROHIBITED.

NO.	DATE	REGION	NAME

PROJECT:	STANDARD ELEPHANT DOOR DRAWINGS	SCALE:	N/A
LOCATION:	N/A	DRAWN BY:	DKH
CUSTOMER:	N/A	CHECKED BY:	
ARCHITECT:	N/A	DATE:	7/5/2017
ENGINEER:	N/A	DATE:	
PROJECT NO.:		DATE:	
PROJECT CODE:		DATE:	
PROJECT STATUS:	STD	DATE:	
PROJECT CODE:	SDS	DATE:	